

A Yang Data Model for Optical Impairment-aware Topology

draft-ietf-ccamp-optical-impairment-topology-yang-16

Co-authors (frontpage):

- Dieter Beller (Nokia)
- Esther Le Rouzic (Orange)
- Italo Busi (Huawei)
- Gabriele Galimberti (individual)
- [Sergio Belotti \(Nokia\)](#)

Co-authors:

- Roberto Manzotti (Cisco)
- Haomian Zheng (Huawei)
- Nicola Sambo (Scuola Superiore S.Anna)
- Julien Meuric (Orange)
- Enrico Griseri (Nokia)
- Gert Grammel (Juniper)
- Jean Luc Auge (Orange)
- Young Lee (Samsung)
- Victor Lopez (Nokia)

Contributors

- Jonas Martenson (Smartoptics)
- Aihua Guo (Futurewei)

Updates Since IETF 119

- Closed ALL remained issues

- I-D text updates

- Issue [#174](#) improve section "2.6.1. Standard Modes" explaining the usage of the optional attributes that were added to the standard-mode
- Issue [#145](#) update security consideration (related to T. Petch comments [#144](#))
- Issue [#171](#) Fix references to RFC9093: reference only RFC9093-bis as a normative reference

- YANG model changes details

- Issue [#167](#) added a key in some specific list to permit to move the model from RO to RW some nodes in backward compatibility way
- Issue [#124](#) changed key in media-channel list and remove flexi-n (value 'N' used to determine the nominal central frequency) that is not present in case of remote TSP
- Issue [#169](#) changed description of “total-loss” leaf in the fiber parameters (added also new text in I-D section 2.9 on “optical fiber”)
- Issue [#172](#) Changed type for operational-mode into string due to operational issue

Next Steps

- Status of the draft
 - The YANG model is stable and text have been improved where needed
 - We think that the draft is ready for WG LC
- We think that due to the dependency on RFC9093-bis and the good status also of that draft it would better to have WG LC together

There is an official weekly CCAMP WebEx meetings (Tue, 2-3pm CET) on the subject, everybody is welcome to attend

- <https://mailarchive.ietf.org/arch/browse/ccamp/?q=optical%20impairments%20invitation>

backup

A YANG Data Model for Layer 0 Types

draft-ietf-ccamp-rfc9093-bis-10

Co-authors (frontpage):

- Sergio Belotti (Nokia)
- Italo Busi (Huawei)
- Dieter Beller (Nokia)
- Esther Le Rouzic (Orange)
- A. Guo (Futurewei)

Contributors

- D. King (University of Lancaster)
- Haomian Zheng (Huawei)
- Y.Lee (Samsung)
- Gabriele Galimberti
- D. Dhody (Huawei)
- B.Y. Yoon (ETRI)
- R. Vilalta (CTTC)
- Enrico Griseri (Nokia)
- V. Lopez (Nokia)

Updates Since IETF 119

- Only 2 remaining issues
- Closed issues: I-D text and YANG updates
 - Issue [#98](#) addressed all Adrian Farrel comments
 - Issue [#79](#) Align references between YANG and I-D
 - Issue [#40](#) Added section with description of the changes from RFC9093
 - Issue [#97](#) Resolved all TBDs in the text
 - Issue [#83](#) Successfully checked , with pyang cmd “--check-update-from”, that all the changes are BC with respect to RFC9093
 - Issue [#99](#) Align title and abstract with RFC8776 and L1-Types
 - Issue [#6](#) Added standard reference for some data nodes attributes and identities.

L0/L1 boundary (1)

Transponder encompass not only L0 functionality but also L1 e.g. inverse multiplexing and FEC

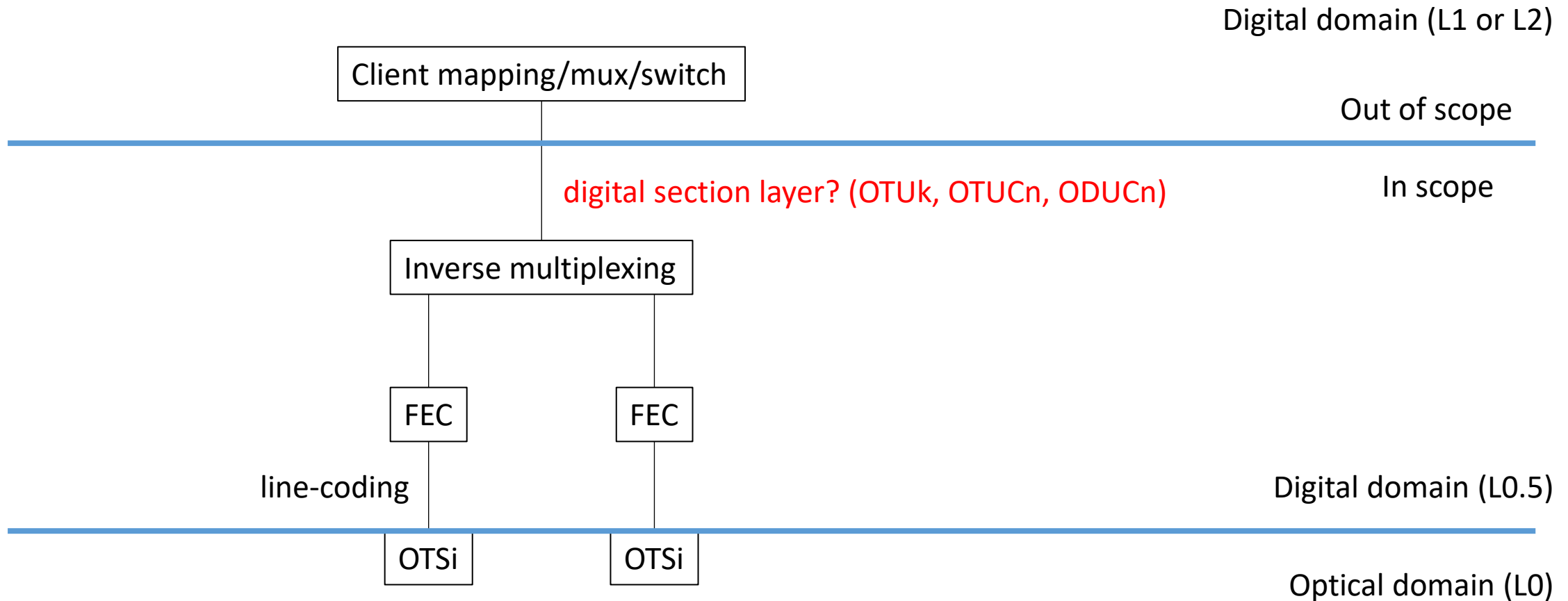

L0/L1 boundary : what is the problem

- While L0 application-code defined in ITU-T provide a clear identification of the photonics signal up to the modulation and FEC format, and the L1 ODU or Ethernet multiplexing schema clearly define the OTN or Ethernet payload structure where present, there is a set of functionality in the middle that are not described in any model.
- The focus of this issue is to find which data nodes attributes could be identified to describe data structure and adaptation between L1 multiplexing and L0 application-code definition.

Non-Hierarchical scenarios (TXP/MXP)

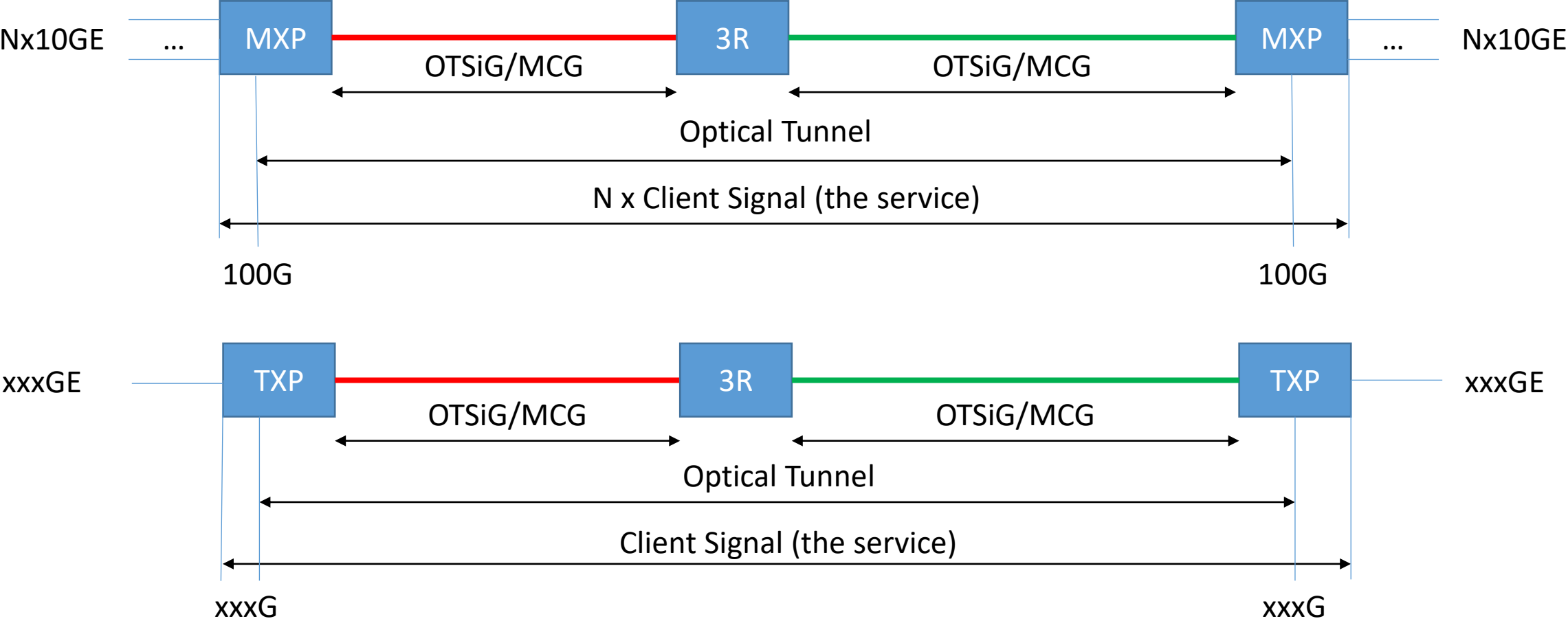

Non-Hierarchical scenarios (TXP/MXP) (2)

- DWDM tunnel fully supports an E2E service that terminates at the client interfaces (e.g. xxxGE)
 - Client signal model configures client interfaces, which tunnel support the service and in case of MXP, the multiplexing label
- We need to identify the parameters that need to be configured in the DWDM tunnel and reported as transponder capability in the topology (e.g. OI), e.g. :
 - Client payload
 - Multiplexing/mapping schema

Hierarchical scenarios (DWDM interface)

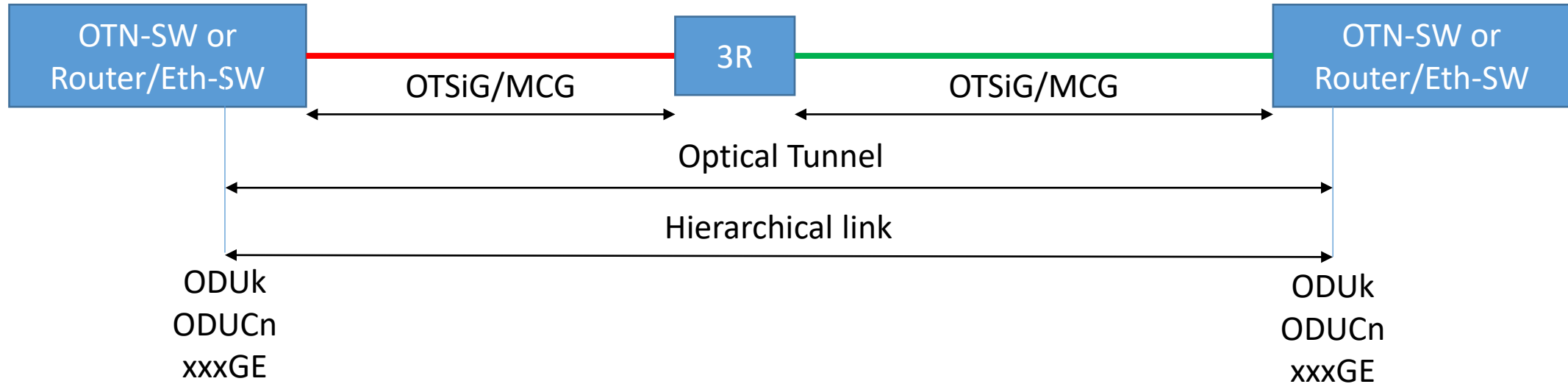

Hierarchical scenarios (WDM interface) (2)

- DWDM tunnel supports a hierarchical link in the client layer (e.g. Ethernet or OTN)
 - The TE tunnel model provides the reference between the TE tunnel and the supported hierarchical link.
 - The max-link-bandwidth of the hierarchical link is defined in RFC8795 (it can be augmented with client layer specific attributes)
- We need to identify the parameters that need to be configured in the DWDM tunnel and reported as transponder capability in the topology (e.g. OI), e.g. :
 - Client payload
 - Multiplexing/mapping schema

Next Steps

- Status of the draft
 - Closed almost all the technical open issues from IETF 118
 - Only one technical open issue left #81
 - The other, #103, is just a new “typeded” for decimal64 to add, we know what to do
 - We think it would be ready for WG LC considering the issues still open to be solved as LC comments.
 - OI and flexgrid-topology are stable and ready for LC .
 - Open WG LC would permit to progress to WG LC also the other 2 drafts

Administrative:

- We have weekly call associated with Optical Impairments aware Topology model on **Tuesday 2pm CET**
- <https://mailarchive.ietf.org/arch/browse/ccamp/?q=optical%20impairments%20invitation>